

Teaching manufacturing processes with computer animations

Marek Balazinski,
marek.balazinski@polymtl.ca

École Polytechnique de Montréal, Mechanical Engineering Department

Marcelo Reggio
marcelo.reggio@polymtl.ca

École Polytechnique de Montréal, Mechanical Engineering Department
P.O. Box 6079, Station Centre-ville, Montréal (Québec) Canada, H3C-3A7

URL: <http://www.cours.polymtl.ca/mec4530/Anim/Menu.swf>

ABSTRACT

Manufacturing processes are often complex and difficult to explain, and expensive to present in a traditional teaching situation. In addition, long laboratory sessions are required to help students understand them. To address these challenges, computer-controlled animations and simulations are proposed for specific processes of interest. Slide shows enhanced with this multimedia content have been incorporated into the Advanced Manufacturing course offered at École Polytechnique de Montréal. Six animations depicting chip formation, cutting forces, machine tool rigidity, plastic chip deformation, tool thermal behavior, and the electrical discharge process have been created. Macromedia Flash MX™ and Corel Draw™ were used to build the animations, which can be consulted at any time through the course website. The interface is interactive, which allows the user to set various parameters and observe how they control the particular process under study.

INTRODUCTION

To enhance the learning process in engineering, numerous efforts are being made to facilitate the students' understanding of theories and practical applications. Among other tools, multimedia is clearly well suited to help them grasp the subtleties and details of complex problems by providing a preliminary overview of the entire process.

Several studies [Kadiyala et al. (2000) and Smith et al. (1992)] find multimedia instruction both more effective and more efficient than conventional educational approaches. More than a decade ago, Shannon (1994), in his study of computer-based multimedia teaching, concluded that in engineering disciplines there is much to be gained through the ability to animate when presenting explanations of how and why a system works.

Altherr et al. (2004) have asserted that the use multimedia for teaching the phenomena of physics can present course material vividly and enable correlations to be easily examined and

analyzed. In addition, it is possible to simulate complicated content and present different levels of abstraction simultaneously, which helps students gain a deeper understanding of that content.

For Van Dijk and Jochems (2002), changing a traditional teaching approach of lectures into an interactive lecture experience is not only feasible, but also improves students' understanding.

In the case of manufacturing processes, students have to achieve a sufficient degree of comprehension of theories related to the strength of materials, heat transfer, the structure of materials, etc. In order to understand these topics, a number of laboratory sessions are required. These sessions are expensive and time-consuming to prepare. As an alternative, computer animations and simulations can be used to show and to modify an individual process of interest.

Many advanced tools are available from the computer graphics community which can be used to develop virtual labs. In this work, Corel DrawTM was used to create the graphics and Macromedia Flash MXTM with the integrated Action ScriptTM language was used to program the animations.

THE CHALLENGE

There are several challenges associated with the development of animations and simulations:

1. Finding an attractive and eye-catching representation to make comprehension easy and enjoyable.
2. Choosing the right level of detail in the presentation of each process. A correct balance between the complexity of the problem and simplification of the presentation needs to be found.
3. Selecting the appropriate number of parameters. As the number of variable parameters increases, the difficulty experienced in grasping their individual influence is also amplified.
4. Defining appropriate illustrations for each phenomenon. These must faithfully depict a phenomenon, while facilitating students' understanding of it. Simulations and animations must convey the essential information with clarity.
5. Matching the students' level of knowledge. Animations and simulations must be targeted to a specific audience.

ANIMATION DESIGN

In this work, two basic types of animations were prepared: interactive and illustrative. The interactive type allows the user to set various parameters and watch the corresponding simulation in real time. Illustrative animations are preconceived scenarios, so that every viewing will be exactly the same.

In order to make animations interactive, they must be programmed in a language recognizable by the animation software. For our situation, the obvious choice was Action Script, an object-based language included in Macromedia Flash MXTM. Each animation contains its own code

linking the parameters to the animation itself. The basic structure is almost the same for every animation.

Interface

The upper-left area is reserved for any custom information about the various parameters. The upper-right area contains the buttons used to perform such basic tasks as screen cleaning (reinitializing), starting the animation, exiting, and others. In the lower area, the user can select the values for each parameter using buttons, sliders, check-boxes, and input areas. Finally, the animation itself is contained in the upper central area. To start the animation, the user sets all the parameters and pushes the start button.

Programming

The animations are programmed with ActionScript, a language similar to C++. The main additions are the built-in methods and properties operating the movie clip frames, such as gotoAndStop() or _currentframe, which are attached to the MovieClip objects. In object-based language terminology, an object is a basic element of a program, such as a rectangle or a movie clip; an object's property is an intrinsic attribute, such as its width or height; an object's method is a function attached to the object, such as double the area or move to the left. The programming consists of creating and manipulating different objects through their properties and methods.

Tweening

Tweening can be defined as the process of generating a set of frames to smoothly animate static objects by changing their position and appearance at specific frames in their lifespan. Taking as an example the tool in Figure 1, we can set a specific path for this object along which it will be moved from one end to the other. This is exactly what is done in this animation, only that, at each frame, the tool's position x is checked and all the necessary attributes are calculated in real time. The flexibility and power of the tweening function depends on the software used. It is also possible to modify the tool's shape during its movement, but in our case that wasn't necessary. Fig. 1 illustrates the tool and its tweening path.

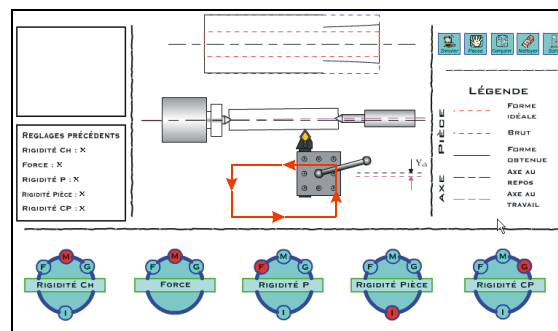

Fig. 1. Object tweening

Buttons

Three basic object types are recognized by Flash: movie clips, buttons, and graphics. Graphics are very rigid and rarely used (actually, they can be completely omitted without causing any harm). The buttons, however, are key to the interaction, and most of the animation's commands are carried out via these objects. In the animation shown in Fig. 1, there are as many as twenty-four buttons. Nineteen of them allow the user to set the parameters, while the remaining six ensure the animation's global commands, as explained above.

ANIMATIONS

Two distinct types of animations were prepared: non-interactive and interactive.

Non-interactive Animations

Non-interactive animations are used to observe a process, and the user is not able to modify any of the parameters. The example shown in Fig. 2 presents various stages of an animation related to a knowledge base using genetic algorithms. It can be seen that the animation is divided into three areas. The area at the top describes the current stage of the process, the central area contains the animation, and the area at the bottom contains a progress bar with all the animation stages and a slider pointing to the current stage.

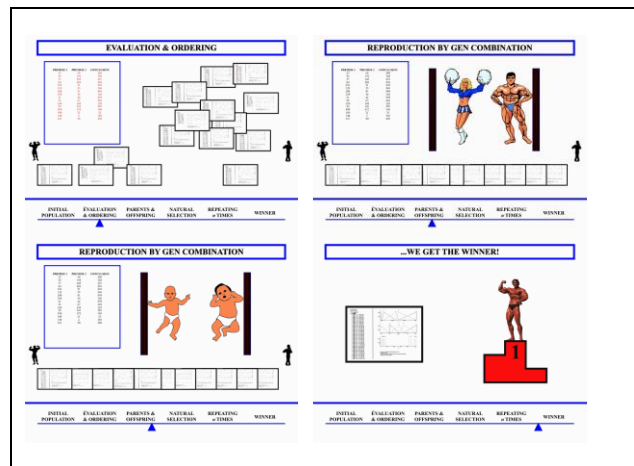

Fig. 2. Stages of automatic generation of fuzzy knowledge bases

Interactive Animations

A total of six animations, presenting a chip compression ratio, types of chips, cutting forces, temperature distribution in the cutting zone, machine tool (lathe) rigidity, and the clustering process, were developed. Students can vary the parameters involved in each process, and observe the influence of that variation on both the process and the results.

Chip compression ratio. This animation, depicted in Fig. 3, allows students to observe the influence of the rake angle (γ) variation on the chip compression ratio using the rake angle slider.

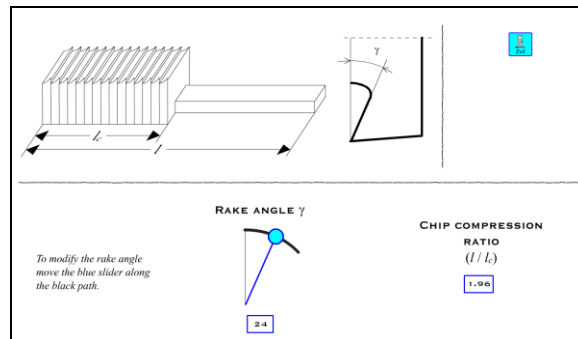

Fig. 3. Screen shot of the chip compression ratio animation

Types of chips. This animation permits students to observe how different parameters (feed and depth of cut) influence the shape of the chip during the turning process. It also makes it possible to distinguish between appropriate and inappropriate chip shapes. The screen shot of this animation is presented in Fig. 4.

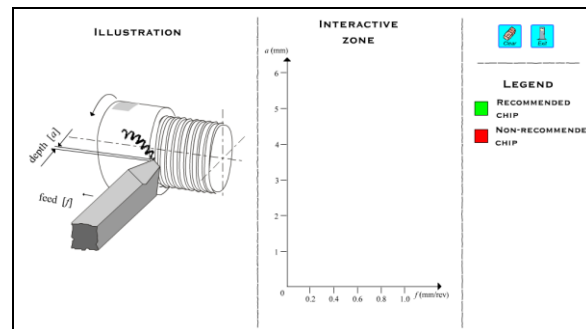

Fig. 4. Screen shot of the type of chip formation simulation

Cutting forces. This simulation permits students to observe the influence of different parameters on the cutting forces. These parameters include the cutting process parameters, tool angles, and tool wear. An example of the animation in process is presented in Fig. 5.

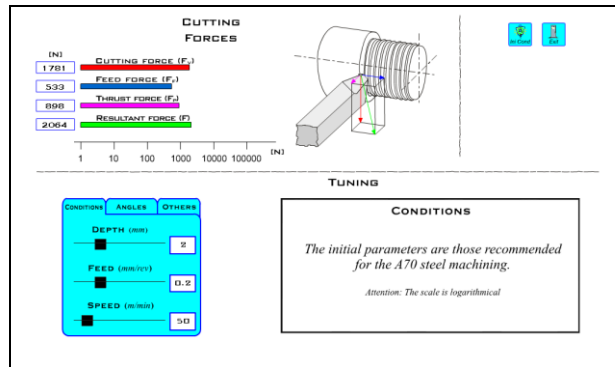

Fig. 5. Screen shot of the cutting forces simulation

Temperature distribution in the cutting zone. This simulation allows students to observe the influence of different machining process parameters on the temperature distribution at the tool-chip interface. The screen shot of this animation is shown in Fig. 6.

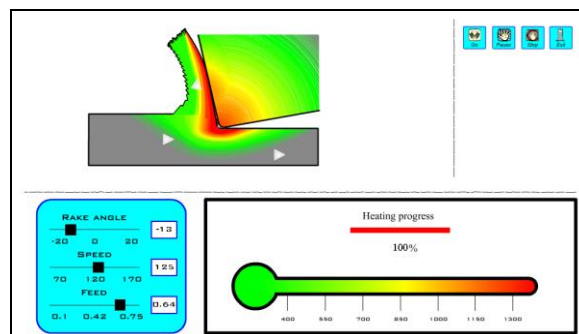

Fig. 6. Screen shot of the temperature distribution simulation

Machine-tool (lathe) rigidity. This animation permits students to experiment with the configuration of various rigidity parameters during the turning process. They can set the rigidity of lathe components (carriage, headstock, tailstock), the rigidity of the workpiece, and cutting force magnitude, and observe the shape of the machined workpiece. It is possible to compare the results of different simulations. The animation may be paused at any time to show the current state of the system deformation. An example of the animation in process is presented in Fig. 7.

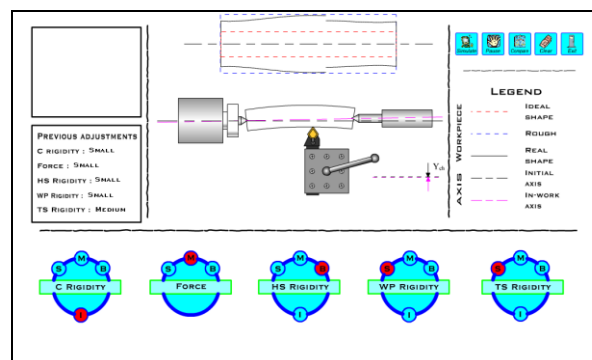

Fig. 7. Screen shot of the rigidity simulation

CONCLUSION

Eight animations were successfully developed in a short period of time on a limited budget by a skilled programmer.

The animations developed in this project have been greatly appreciated by students and conference attendees, who found they helped them understand the material and the presentations. For some students, animations help convey the intuition behind the phenomena. In addition, they present the process without using equations, which may be of particular interest for continuing education purposes.

In order to assess the impacts of the animations on the students' understanding of the problems presented, a quick survey among the 27 students following the lectures was conducted. The survey question was the following: "To what degree, from 1 (not helpful at all) to 5 (very helpful), did the animations help you understand the theory?" The average result obtained was 4.6, which indicates that the animations help students a great deal in understanding technological problems.

The main challenges lie in coming up with the appropriate representations for each phenomenon. With future improvements in software libraries and tools, animations and simulations should become easier to develop.

ACKNOWLEDGMENT

The work presented in this paper was conducted with the support of the Teaching and Learning Center of the École Polytechnique de Montréal, which the authors greatly appreciate.

REFERENCES

Altherr, S., A. Wagner, B. Eckert, and H. J. Jodl, (2004), "Multimedia material for teaching physics," *European Journal of Physics*, vol. 73-1, pp. 7-14.

Kadiyala, M. and B. L. Crynes, (2000) "A Review of Literature on Effectiveness of Use of Information Technology in Education," *Journal of Engineering Education*, pp. 177-189.

Moock, C., (2004), *Essential ActionScript 2.0*, O'Reilly & Associates Inc.

Shannon, G. F., (1994), "Multimedia computer based teaching – A case study," *Proceedings of IEEE International Conference on Multi-Media Engineering Education*, pp. 398-402.

Smith, P. L., T. J. Ragan et al., (1992), "A Review of the Literature Investigating the Learning Benefit of Education Presented in a Multimedia, Individualized Format," Technical Report, Oklahoma University Technology.

Van Dijk, L. A. and W. M. G. Jochems, (2002). "Changing a traditional lecturing approach into an interactive approach," *International Journal of Engineering Education*, vol. 18-3, pp. 275-284.

Corel R.A.V.E. 3.0 Help, (2004), Corel Corporation.